

Outdoor Lighting Requirements

Please read, sign, and attach to the Construction Permit Application

No materials may be brought into the Cape, nor construction started until the permit application has been approved. I agree that if any construction is begun without a valid permit having been issued and conspicuously displayed on the property, non-compliance fees will be assessed and the matter may be turned over to the CCPOA attorney for legal remedy and that I will be liable for attorney fees, court costs, and other applicable fees. I hereby grant reasonable access to my property by members of the ACC and CCPOA Board of Directors to determine compliance and progress until such time as the project is completed.

Cape Carancahua is a Dark Skies compliant community. The installation of outdoor lighting requires a permit to insure that light pollution and nuisance is held to a minimum, while allowing the installed lighting to perform its intended purpose.

Lighting, the shining of light produced by a light fixture beyond the boundaries of the property on which the light fixture is located and onto another property under circumstances where the lighting element of the fixture is visible from such other property and in such a manner and with such intensity as to disturb and annoy the reasonable sensibilities of a person living on and using such other property in a reasonable and customary manner as a residence is declared to be a nuisance and is prohibited. Street lights, traffic control lights, and public facility lighting are exempt.

This includes all exterior lighting affixed to any building, pier or walkway, ground mount, or pole.

Such lighting will in all cases utilize Dark Skies compliant fixtures.

The CCPOA and ACC are responsible only for ascertaining that our building restrictions are met. CCPOA and ACC make no warranty, implied or otherwise, regarding structural/design strengths.

Signature of Property Owner

Lot #(s)

9-1-1 Street Address

Date

Date Received by CCPOA

CCPOA Office Staff Member

UNSHIELDED FIXTURES

Discouraged

Fixtures that produce glare and light trespass

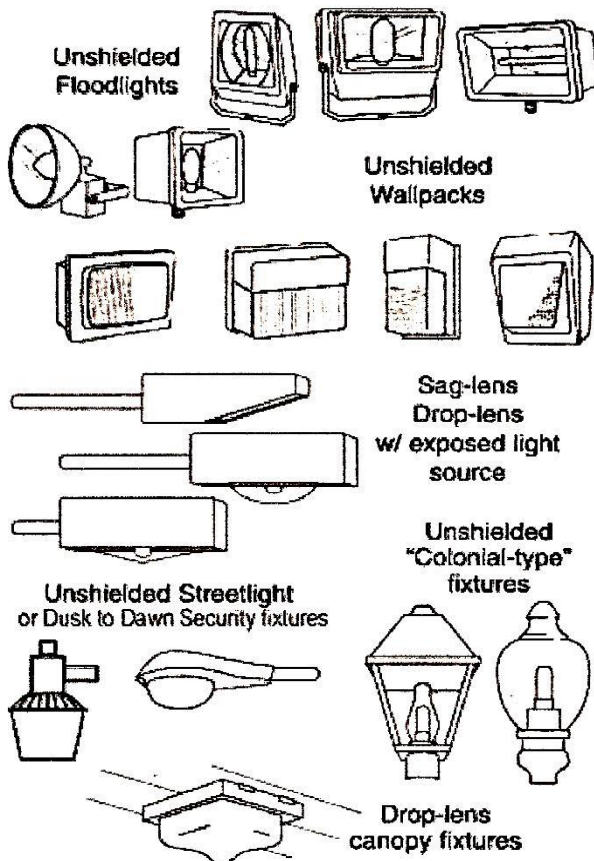

Full Cutoff and Fully Shielded Fixtures

Recommended

Fixtures that shield the light source to reduce glare and light trespass and to facilitate better vision at night.

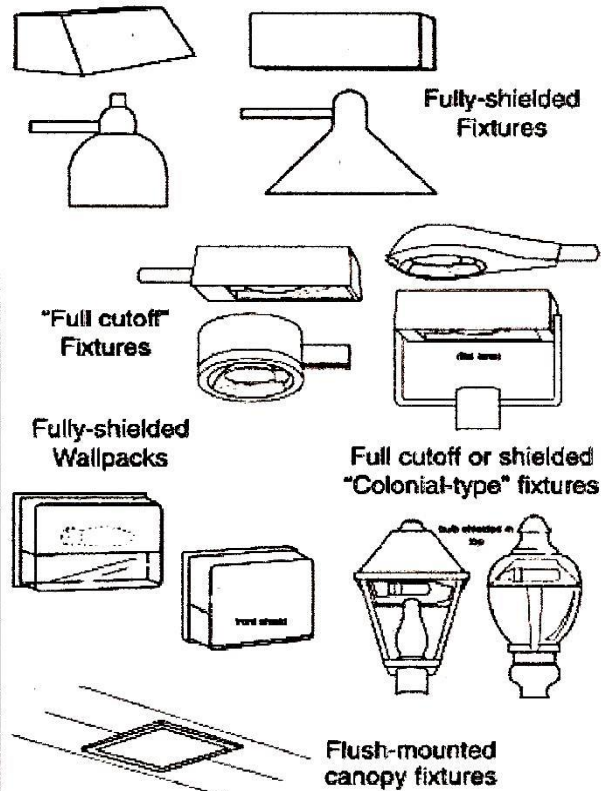

Diagrams courtesy of Bob Crelin

*******Ask your local electrical suppliers for "full-cut off" or "fully shielded" light fixtures. Once you have selected fixtures which are compatible with your architecture and community, contact the manufacturer's representative to see a sample of the fixture(s) and to ask for a free lighting plan. If you have a CAD file, the plan can be easily provided in a short period of time. *******

Most lighting manufacturers have Application Departments which will execute free lighting plans to meet local lighting codes.

See this website for links to manufacturers:

<http://www.darksky.org/mc/page.do?sitePageId=56422&orgId=idsa>

Sample of Web retailers:

www.starrynightlights.com and www.greeneearthlighting.com